

DL1000M

SCR Generator Set

Land Rig SCR Power

- Designed and built to meet the demanding requirements of the drilling contractor

High Reliability

- Rugged design
- Easy maintenance
- Long service life

Low Operating Cost

- High fuel efficiency
- Long service intervals

Meets Most International Specifications



See back for generator specifications!

STANDARD EQUIPMENT

- EPA Tier 2 non-road certified
- Electronic engine controls
- Generator space heater
- Stator RTDs
- Heavy duty, structural steel base
- Lifting provisions
- Spill containment w/drain connection
- Fuel supply/return connections
- Electric starter 24 VDC
- Batteries, 12V lead calcium (2)
- Battery boxes, polyethylene (2)
- Alternator, engine-mounted
- Dry type air filter, heavy duty
- Service indicator
- Air intake shutoff valve
- Radiator, 122°F (50°C)
- Blower fan, engine belt driven
- Lube oil filters
- Engine mounted oil cooler
- Fuel filters, primary & secondary
- Control Panel, unit-mounted
- Shutdowns and Alarms
 - High Jacket Water Temperature
 - Low Oil Pressure
 - High Oil Temperature
 - Engine Over Speed
 - Engine Failed to Start
- Engine hours meter
- Start/Stop switch
- Emergency Stop switch

OPTIONS

- Generator air filters
- Bearing RTD (1 per)
- Air starting system
- Dual air/electric starting system
- Battery charger, float type
- Exhaust System Silencers
- Rain caps
- Exhaust flexible connections, SS
- Radiator, 131°F (55°C)
- Remote cooling package
- Copon coating
- Lube oil heating system
- Duplex fuel filters
- Fuel/water separator
- Control Panel, remote-mounted



Building For The Next Century

DL1000M SCR Generator Set

RATINGS

DRILLING (PRIME) KWE/KVA RATING @ 60 HZ*	997/1424
RATED VOLTAGE	600/346 VAC
RATED FREQUENCY	60 HZ
RATED POWER FACTOR (LAGGING)	0.7

* At voltage, frequency and PF according to ISO 3046/1 conditions.

ENGINE

MANUFACTURER	MTU
MODEL	12V4000
TYPE	4 cycle
FUEL	Diesel
CYLINDERS	V-12
POWER OUTPUT (HP)	1481
SPEED (RATED)	1200 RPM

GENERATOR

TYPE	Brushless
POLES	6 pole
STATOR	Form wound
BEARING	Dual, sealed
INSULATION	Class H
TEMPERATURE RISE @40 °C	80 °C
VOLTAGE REGULATION	DVR

DIMENSIONS

WEIGHT (APPROX.)	33,500 lbs
L x W x H (IN INCHES)	246 x 54 x 121

All dimensions are in inches and are approximate. Air filters to be shipped loose, max dimensions shown.

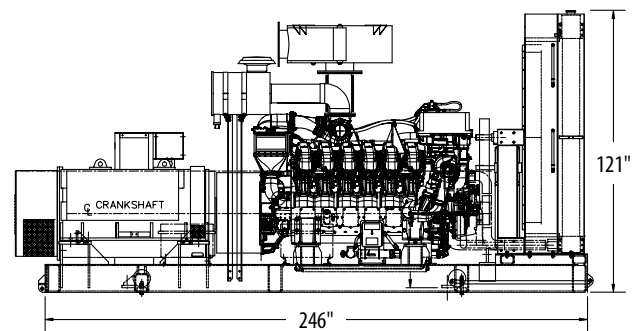
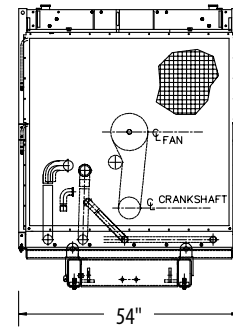

Albuquerque, NM
+1 505-881-3511

Corpus Christi, TX
+1 361-289-5350

Gillette, WY
+1 307-685-6413

New Orleans, LA
+1 504-347-4326

San Antonio, TX
+1 210-662-1000

Broussard, LA
+1 337-837-9001

Dallas, TX
+1 214-631-5370

Houston, TX
+1 713-671-6220

Odessa, TX
+1 432-620-4500

Waco, TX
+1 254-857-4351

Casper, WY
+1 307-234-6975

El Paso, TX
+1 915-790-1848

Longview, TX
+1 903-758-5562

Pharr, TX
+1 956-787-6880

Wichita Falls, TX
+1 940-322-5227

Commerce City, CO
+1 303-287-7441

Farmington, NM
+1 505-325-5071

Lubbock, TX
+1 806-745-4224

Pueblo, CO
+1 719-543-7056

Visit us on the Web at www.stewartandstevenson.com

SSLLC2007-04-011 ©2007 STEWART & STEVENSON

All data subject to change without notice. The information in this bulletin is believed to be accurate but all recommendations are made without warranty, since the conditions of use are beyond Stewart & Stevenson's control. Stewart & Stevenson disclaims any liability in connection with the use of this information, and does not warrant against infringement by reason of the use of any of its products in combination with other material or in any process. Stewart & Stevenson warrants only that the product complies with specifications agreed to in contracts of sale.



Building For The Next Century